

**STRAIGHT SQUARE FLANGE JACK
CLAMP TYPE - CABLE 6/75+93 S**

R161.262.000
SERIES N

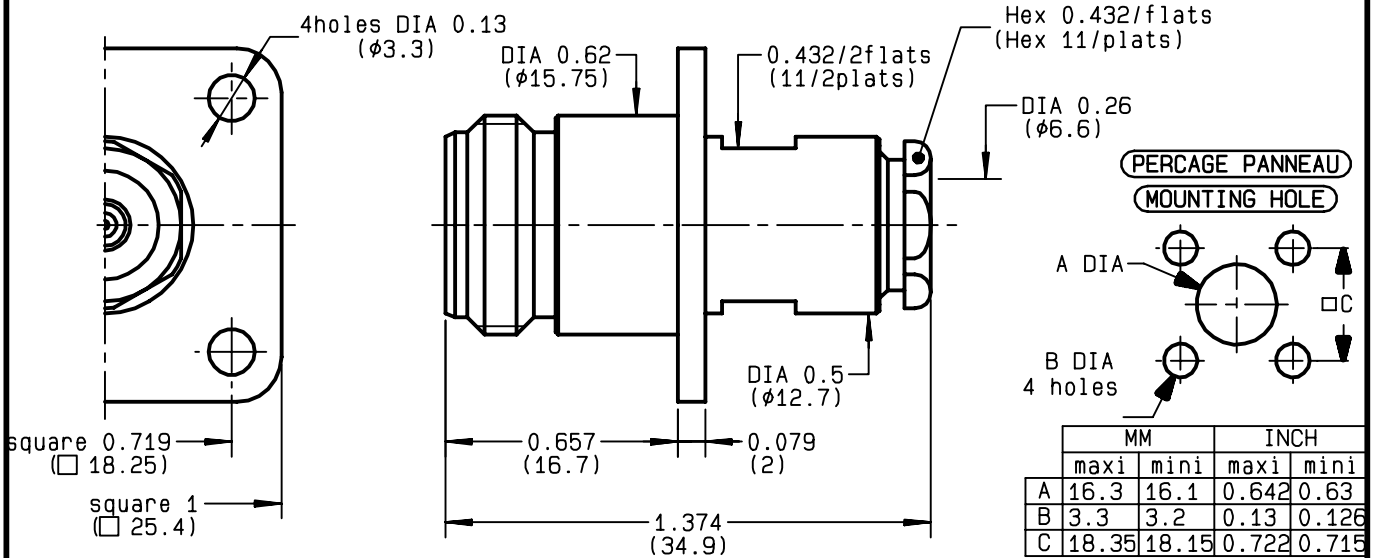

NOMINAL IMPEDANCE	50 Ω
FREQUENCY RANGE	0-11 GHz
TEMPERATURE RATING	-55/+155 °C
V.S.W.R	NA + x F(GHz)Maxi
RF INSERTION LOSS	0.048 √F (GHz) dB Maxi
VOLTAGE RATING	850 Veff Maxi
DIELECTRIC WITHSTANDING VOLTAGE	1500 Veff Mini
INSULATION RESISTANCE	5000 MΩMini
HERMETIC SEAL	NA Atm.cm ³ /s
LEAKAGE (pressurized only)	NA
MECHANICAL DURABILITY	500 Cycles
WEIGHT	36.6 gr
SPECIFICATION	

CABLES : **BICC T3304**
KX 6A
RG 59
RG 62
RG 71

OTHERS CHARACTERISTICS

CABLE RETENTION	200 N Mini
CENTER CONTACT RETENTION	
Axial force - mating end	NA N Mini
Axial force - opposite end	27 N Mini
Torque	NA cm.N Mini
RECOMMENDED TORQUES	
Mating	NA cm.N
Panel nut	NA cm.N
Clamp nut	450 cm.N

CONNECTOR PARTS	MATERIALS	FINISH	(all values are given in micrometers)
BODY	BRASS	BBR 2	
OUTER CONTACT	BRASS	BBR 2	
CENTER CONTACT	BERYLLIUM COPPER	GOLD 0.5 OVER NICKEL 2	
INSULATOR	PTFE	-	
GASKET	SILICONE RUBBER	-	
OTHERS PIECES	BRASS	BBR 2	

BONMINI

ISSUE	CREATION DATE	FILE PART-NUMBER
9812R01	19/10/1992	EPC 96-07



RADIALL®

The information given here is subject to change without notice.
Design changes may be in order to improve the product .

Connect to the future



R161.262.000

ISSUE **9812R01** SERIES **N**

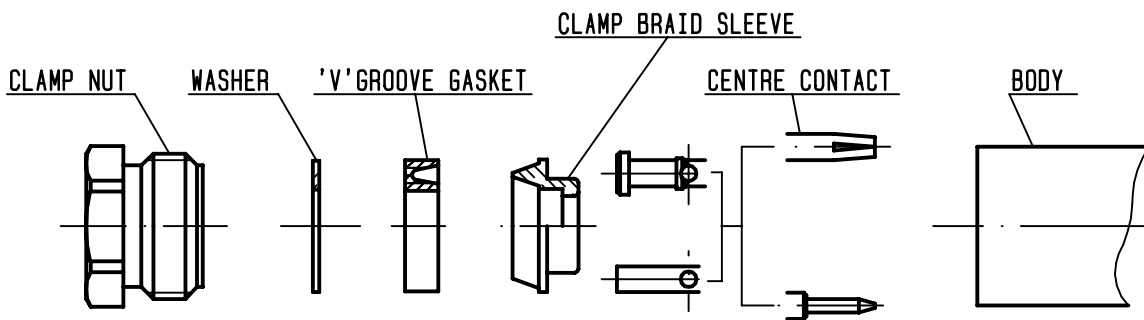

①

Strip the cable .

-
-
-
-

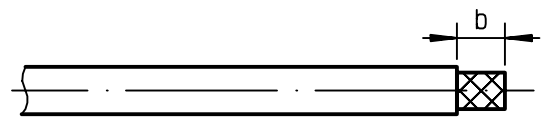

Stripping	a	b	c	d	e
inch	0.157	0.295	0	0	0.039
mm	4	7.5			1

②

Slide the clamp nut , the washer and the 'V'groove gasket onto the cable .
 Slide clamp braid sleeve over braid .
 Fold back braid and trim off surplus braid .
 Trim back dielectric as shown .
 -
 NOTA: For air-space PE cables , "e" = 0 .
 Introduce insulator onto dielectric cable .

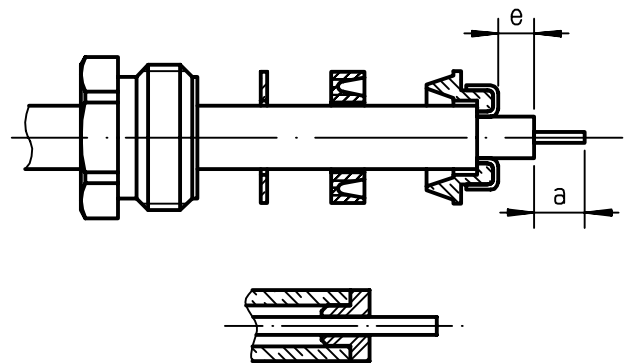

③

Solder the cable inner conductor into centre contact .

-
-
-
-

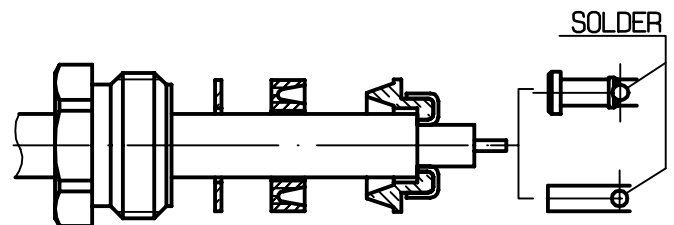

④

Screw sub-assembly into the connector body .
 (recommended coupling torque 39.82 in.lb)

-
-

